



PROJECT		REF		REV	ITEM CODE	
LOCATION		DATE			Page	

## SANITARY WARE SPECIFICATION SHEET

Item Descriptions	Stern (Israel) "Foot Washfree" Chrome plated wall mounted sensor foot washer in DC Supply with <b>internal 9V battery box</b> ; top access replacement of batteries	Illustration/ Drawing
Model	Foot Washfree	
Code Number	113730	
Finish	Chrome Plated	
Supplier	Acme Sanitary Ware Co. Ltd Mr. Eric Wong/ Mr. Don Yuen	
Contact Tel/Fax	(852) 2388-7171 / (852) 2710-8012	
E-mail	acme@acmesanitary.com.hk	
Website	www.acmesanitary.com.hk	

**FOOT WASH FREE Ref # 113730**

Electronically operated self closing foot washer. Activated by touching the designated area in the middle of the piezo cap. Solid brass construction. Filter included. All components are located inside the product body. Flow restrictor options: 6, 7 or 9 LPM. the foot wash will automatically shut off after the default factory set flow time of 8 seconds passes. The default flow time is adjustable on site if desired.

**Application:**  
 Provides an accurate discharge controlled electronically. Maximizes hygiene and saves water. Ideal for swimming pools, beaches and ritual feet washing.

**Use:**  
 When a user touches the designated area on the Piezo cap, a flow cycle of 8 seconds will be completed. If the user does not need more water, he can touch the designated area to stop the water flow before the default time has passed.

PRODUCT AT A GLANCE			
Installation	Exposed wall mounted		
Power Supply	9V battery		
Operating pressure	1.0-6.0 bar (15.0-88.0 PSI)		
Water supply	Cold and premixed water		
Water flow	9 LPM / 2.38 GPM		
Water Saving Options	7 LPM / 1.85 GMP / 6 LPM / 1.59 GMP - Flow restrictor		
Flow Time	8 seconds default factory time. Adjustable on site		
ORDERING INFORMATION			
MODEL	CODE	POWER	ADDITIONAL SPECIFICATIONS
FOOT WASHFREE	113730	9V battery	Exposed Installation

- Installation:**  
Wall mounted exposed
- Water supply:**  
Cold or premixed water (1 inlet)
- Water temperature:**  
Max 70 °C
- Operating pressure:**  
0.5 - 8.0 bar
- Power source:**  
9V Lithium battery



\* All information of the above is for the reference only. No prior notice is made if any changes.



PROJECT		REF		REV	ITEM CODE	
LOCATION		DATE			PAGE	

## SPARE PARTS LIST

Foot Washfree (113730)

Quantity	Part Number	Description	Cat. No.
	-	<b>Seals and Screws Kit</b>	<b>07210148</b>
2	2	Screw	
1	3	O-ring	
1	8	O-ring	
1	9	O-ring	
1	10	O-ring	
1	11	O-ring	
1	12	Screw	
1	13	Screw	
2	15	Screw	
2	16	Anchor	
	<b>7</b>	<b>Filter</b>	<b>08530013</b>
	<b>1</b>	<b>Cover Kit</b>	<b>07270194</b>
	-	<b>Solenoid Valve Kit</b>	<b>07230002</b>
1	4	Solenoid valve	
1	5	Diaphragm	
	<b>5</b>	<b>Diaphragm</b>	<b>04500001</b>
	-	<b>Spray Plate+Screw Kit</b>	<b>07212013</b>
1	13	Screw	
1	14	Spray plate with nozzles	

**Note:** In order to locate the relevant spare part, please check the corresponding parts and part number in the drawing. Minimum order quantity will be required.

\* All information of the above is for the reference only. No prior notice is made if any changes.



# FOOT WASHFREE



ELECTRONICALLY OPERATED SELF CLOSING  
FOOT WASHER OPERATED BY TOUCH

Operated by a Piezo element integrated in the foot washer cap.  
For cold or premixed water.

**Advantages:**

- Drastically reduces water consumption
- No moving parts, ideal for heavy duty areas
- Non hold open feature
- More possibilities to save water: the water flow can be stopped in the middle of the cycle
- Stable and accurate water flow that can be changed on site
- Ideal for swimming pools, beaches and ritual foot washing
- Heavy duty chrome plated brass construction
- Silicone nozzles for easy cleaning
- Easy installation

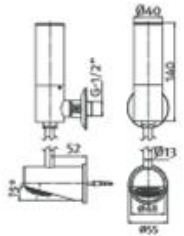

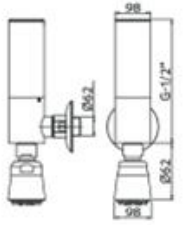
PICTURE	PRODUCT NAME	MODEL FEATURES	POWER SUPPLY	CODE NUMBER	DRAWING
	FOOT WASHFREE	Exposed installation	Internal 9V battery	113730	
	FOOT WASHFREE 3000	Exposed installation. Directional shower head	Internal 9V battery	113720	



## INSTALLATION

### FOOT WASHFREE

#### STEP 1- INSTALLING THE FOOT WASHER

1

Shut off the water supply.



2

Remove the hexagonal nut, the disk and the gasket. Do not remove the O-ring from the base of the faucet.

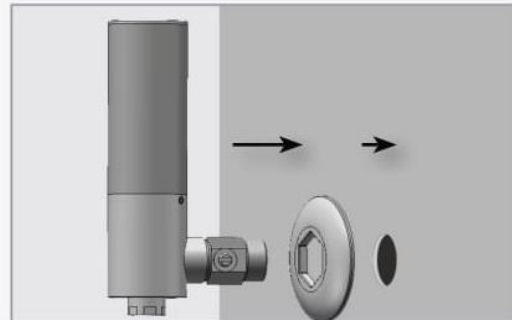

3

Place the faucet with O-ring into the hole in deck or lavatory. Make sure the O-ring is located between the deck or lavatory and the bottom of the faucet.

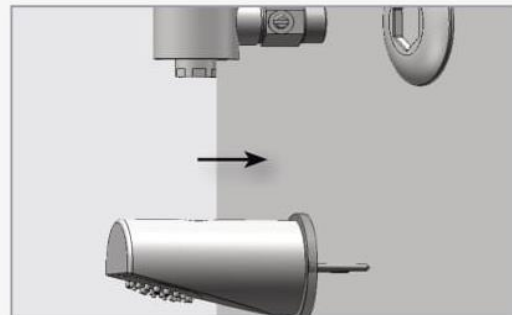

4

Slide the gasket, disk and hexagonal nut over the flexible hose and secure the faucet into place.

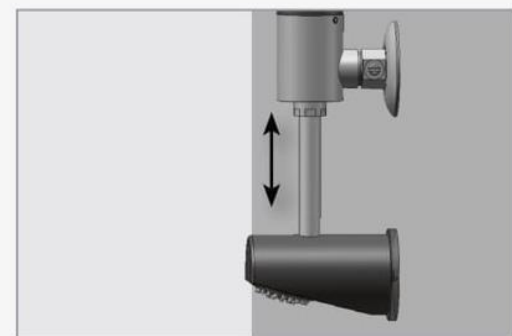

NOTE: If needed, cut the pipe to match the distance between the Alcalá body and the shower head.





## INSTALLATION

## FOOT WASHFREE

### STEP 2 – CONNECTING THE WATER SUPPLY

1

Turn on the central water supply and the shut-off valves and check for leaks.



2

Ensure that the regulating valve is fully open by turning it anti-clockwise.

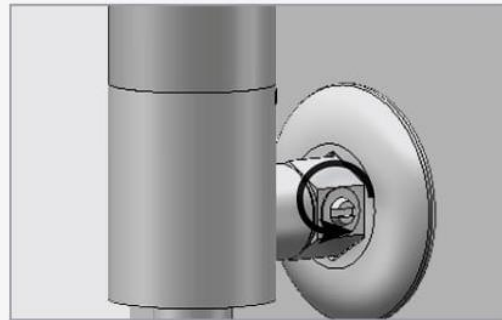



## FLOW TIME ADJUSTMENT

### ADJUSTMENT LEVELS

The flow time is programmable on site. If necessary, the default flow time of 8 seconds can be adjusted to any value between 1 to 60 seconds. The Alcalá adjustment mechanism is composed of 3 adjustment levels for changing the flow time. An indicator light (LED) will guide you from one level to the other.

The following table shows the number of steps in each level, the duration of each step and how to recognize in what adjusting level you are.

	Level 1	Level 2	Level 3	Out of adjusting mode
No. of steps	10 steps	10 steps	2 steps	
Seconds to be increased by touching once	1 second	2 seconds	15 seconds	
Adjustment level indicator	After entering into adjusting mode level 1 is reached	Indicator light blinks twice	Indicator light blinks 3 times	Indicator light blinks 4 times

### HOW TO ADJUST THE FLOW TIME IN ALCALA

- 1) Open the piezo cap using the provided 2 mm Allen key.
- 2) Disconnect the internal battery.
- 3) Touch the piezo cap twice.
- 4) Then, reconnect the battery.
- 5) The indicator light (LED) on the back of the Piezo cap will start blinking. After a few blinks the LED will give a steady red light. Touch the Piezo cap when the steady red light is still on to enter into the adjusting mode. When done correctly, the light will stop blinking.

NOTE: If you will not press at the indicated area, the previous adjustment will remain.

- 6) By touching the Piezo cap the new flow time will be programmed.  
In adjusting mode level 1, each touch increases the flow time by 1 second with a maximum of 10 seconds. You will see the LED blinking every time that a new step is performed.

- 7) If your desired flow time is within 10 seconds, no other adjusting levels are needed and you can stop pressing the Piezo cap. The LED will blink 2 times, then 3 times and after 4 times you will leave the adjusting mode.

The Foot Washfrees now adjusted to the desired flow time.

- 8) If you need to perform steps at adjusting level 2, wait until you see the LED blink twice and then, perform the needed quantity of steps (with a maximum of 10 steps of 2 seconds).



## FLOW TIME ADJUSTMENT

If you do not need more levels, stop pressing. The indicator light will blink 3 times and after 4 times you will leave the adjusting mode. The Alcalá is now adjusted to the desired flow time.

9) If you need to perform steps at adjusting level 3, wait until you see the LED blink 3 times and then, perform the needed quantity of steps (with a maximum of 2 steps of 15 seconds).

10) To leave the adjusting mode wait until the LED blinks 4 times. The Foot Washfree is now adjusted to the desired flow time.

## MAINTENANCE

### FILTER CLEANING INSTRUCTIONS

The system is provided with two stainless steel filters preventing foreign particles to enter the lines. If the water flow has decreased, this may be because the filters are clogged. The filters can be cleaned as follows:

1. Shut-off the water shut off valve.
2. Disassemble the Alcalá, and remove the filter located between the body and the shut off valve.
3. Wash the filter under running water.
4. Reassemble the parts.
5. Make sure that there is no water leakage.

### CARE AND CLEANING OF CHROME AND SPECIAL FINISHES

DO NOT use steel wool or cleansing agents containing alcohol, acid, abrasives, or the like. Use of any prohibited cleaning or maintenance products or substances could damage the surface of the faucet.

For surface cleaning of faucets use ONLY soap and water, then wipe dry with clean cloth or towel. When cleaning bathroom tile, the faucets should be protected from any splattering of harsh cleansers.









## BATTERY REPLACEMENT

### LOW BATTERY INDICATOR

Alcala has an advanced battery level management system consisting of two steps. In the first step, the battery still has enough power to open and close the solenoid valve and allows the solenoid valve to open.

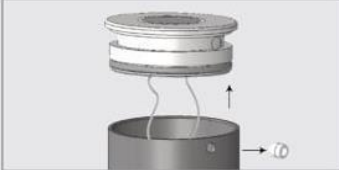
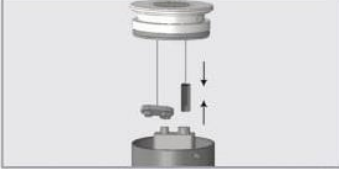
In the second step the battery might not have enough power to open and close the solenoid valve. In this case, the battery level management system does not allow the solenoid valve to open. Instead of providing an opening and closing pulse, the systems provides two closing pulses.

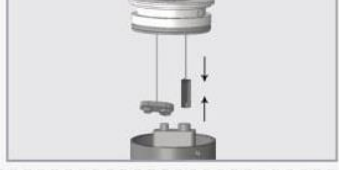
### BATTERY REPLACEMENT INSTRUCTION

1	Unscrew the M4X4 Allen screw on the Alcala cap and pull out the piezo cap.	
2	Disconnect the connectors and take out the old battery.	
3	Replace the used battery with a new 9V battery. A lithium battery is recommended.	
4	Reconnect the connectors between the battery and Piezo cap.	
5	Place the Piezo cap back into place and tighten the Allen screw.	

#### NOTE:

- Do not allow moisture or water into the system while the battery is being replaced.
- The interior of the shower control must be fully dry before reassembling the parts. If it is not fully dry, carefully dry it.





## SERVICE CHECK LIST

No water is coming out

Check the battery. Low or used up battery. Replace the battery.

Check the flow time.

Check the connection between the piezo cap connector and the solenoid connector.

Check the solenoid valve. If debris or scale are present, unscrew the solenoid valve, pull out the plunger and the spring and clean them.

Use scale remover if needed. When replacing the spring, make sure that it is in vertical position.

Check the diaphragm. If needed, clean the orifice or replace it.

Check the water supply pressure. It must be 0.5-8.0 bar (7-116 PSI) . With water pressure of more than 8 Bars, use a pressure reducing valve.

Water flow does not stop

Check the flow time. If needed adjust it following the instructions.

Check the solenoid valve. If debris or scale is present, unscrew the solenoid valve, pull out the plunger and the spring and clean them.

Use scale remover if needed. When replacing the spring, make sure that it is in vertical position.

Water flow diminished

Check the filter. If needed, remove it, clean it and reinstall it.